



ST1300PA POLICE

OWNER'S MANUAL

Honda ST1300PA

OWNER'S MANUAL

IMPORTANT INFORMATION

- **OPERATOR ONLY. NO PASSENGER**

This motorcycle is designed and constructed as an operator-only model. The seating configuration does not safely permit the carrying of a passenger. Do not exceed the maximum weight capacity.

- **ON-ROAD USE**

This motorcycle is designed to be used only on the road.

- **READ THIS OWNER'S MANUAL CAREFULLY**

Pay special attention to the safety messages that appear throughout the manual. These messages are fully explained in the "A Few Words About Safety" section which appears before the Contents page.

This manual should be considered a permanent part of the motorcycle and should remain with the motorcycle when resold.

Honda ST1300PA OWNER'S MANUAL

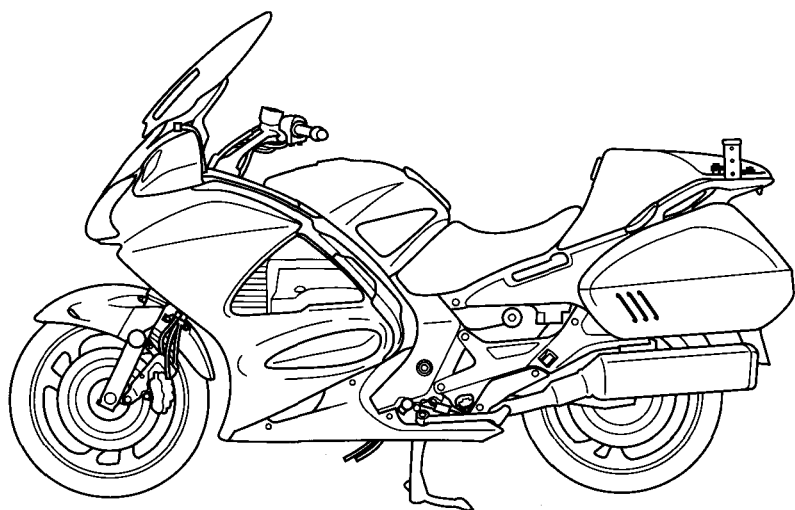

All information in this publication is based on the latest production information available at the time of approval for printing. Honda Motor Co., Ltd. reserves the right to make changes at any time without notice and without incurring any obligation.

No part of this publication may be reproduced without written permission.

WELCOME

The motorcycle presents you a challenge to master the machine, a challenge to adventure. You ride through the wind, linked to the road by a vehicle that responds to your commands as no other does. Unlike an automobile, there is no metal cage around you. Like an airplane, a pre-ride inspection and regular maintenance are essential to your safety. Your reward is freedom.

To meet the challenges safely, and to enjoy the adventure fully, you should become thoroughly familiar with this owner's manual BEFORE YOU RIDE THE MOTORCYCLE.

As you read this manual, you will find information that is preceded by a **NOTICE** symbol. This information is intended to help you avoid damage to your motorcycle, other property, or the environment.

When service is required, remember that your Honda dealer knows your motorcycle best. If you have the required mechanical "know-how" and tools, your dealer can supply you with an official Honda Service Manual to help you perform many maintenance and repair tasks.

Pleasant riding, and thank you for choosing a Honda !

-
- The following code in this manual indicates the country.

U	Australia
---	-----------

- The specifications may vary with each locale.

A FEW WORDS ABOUT SAFETY

Your safety, and the safety of others, is very important. And operating this motorcycle safely is an important responsibility.

To help you make informed decisions about safety, we have provided operating procedures and other information on labels and in this manual. This information alerts you to potential hazards that could hurt you or others.

Of course, it is not practical or possible to warn you about all hazards associated with operating or maintaining a motorcycle. You must use your own good judgment.

You will find important safety information in a variety of forms, including:

- **Safety Labels** — on the motorcycle.
- **Safety Messages** — preceded by a safety alert symbol  and one of three signal words: **DANGER**, **WARNING**, or **CAUTION**.

These signal words mean:

⚠ DANGER

You **WILL** be **KILLED** or **SERIOUSLY HURT** if you don't follow instructions.

⚠ WARNING

You **CAN** be **KILLED** or **SERIOUSLY HURT** if you don't follow instructions.

⚠ CAUTION

You **CAN** be **HURT** if you don't follow instructions.

- **Safety Headings** — such as Important Safety Reminders or Important Safety Precautions.
- **Safety Section** — such as Motorcycle Safety.
- **Instructions** — how to use this motorcycle correctly and safely.

This entire manual is filled with important safety information — please read it carefully.

CONTENTS

OPERATION

Page

1 MOTORCYCLE SAFETY

- 1 IMPORTANT SAFETY INFORMATION
- 3 PROTECTIVE APPAREL
- 4 LOAD LIMITS AND GUIDELINES
- 8 SAFETY LABELS

11 PARTS LOCATION

- 14 INSTRUMENTS AND INDICATORS
- 18 MULTI-DISPLAY

28 MAJOR COMPONENTS

(Information you need to operate this motorcycle)

- 28 REAR SUSPENSION
- 30 BRAKES
- 33 CLUTCH
- 34 COOLANT
- 36 FUEL
- 39 ENGINE OIL
- 40 FINAL DRIVE OIL
- 41 TUBELESS TYRES

46 ESSENTIAL INDIVIDUAL COMPONENTS

- 46 IGNITION SWITCH
- 47 RIGHT HANDLEBAR CONTROLS
- 49 LEFT HANDLEBAR CONTROLS
- 50 WINDSCREEN HEIGHT ADJUSTMENT SWITCH
- 51 HAZARD WARNING SYSTEM SWITCH

Page

52 FEATURES

(Not required for operation)

- 52 STEERING LOCK
- 53 SEAT
- 55 SADDLEBAGS
- 57 FAIRING POCKETS
- 58 WINDSCREEN HEIGHT ADJUSTMENT
- 59 DOCUMENTS
- 60 REARVIEW MIRRORS
- 61 HEADLIGHT AIM VERTICAL ADJUSTMENT
- 62 CLIP
- 63 FUEL TANK MAINTENANCE POSITION

65 OPERATION

- 65 PRE-RIDE INSPECTION
- 66 STARTING THE ENGINE
- 68 RUNNING-IN
- 69 RIDING
- 70 BRAKING
- 73 PARKING
- 74 ANTI-THEFT TIPS

CONTENTS

MAINTENANCE

Page

75 MAINTENANCE

75	THE IMPORTANCE OF MAINTENANCE
76	MAINTENANCE SAFETY
77	SAFETY PRECAUTIONS
78	MAINTENANCE SCHEDULE
80	SERIAL NUMBERS
81	COLOUR LABEL
82	COVER REMOVAL
86	AIR CLEANER
87	ENGINE OIL
92	SPARK PLUGS
94	THROTTLE OPERATION
95	IDLE SPEED
96	COOLANT
97	FINAL DRIVE OIL
98	FRONT AND REAR SUSPENSION INSPECTION
99	SIDE STAND
100	WHEEL REMOVAL
108	BRAKE PAD WEAR
109	BRAKE SYSTEM INSPECTION
110	BATTERY
112	FUSE REPLACEMENT
114	BULB REPLACEMENT

118 CLEANING

122 STORAGE GUIDE

122	STORAGE
123	REMOVAL FROM STORAGE

124 SPECIFICATIONS

126 CATALYTIC CONVERTER

127 NOISE CONTROL SYSTEM

MOTORCYCLE SAFETY

IMPORTANT SAFETY INFORMATION

Your motorcycle can provide many years of service and pleasure — if you take responsibility for your own safety and understand the challenges that you can meet on the road.

There is much that you can do to protect yourself when you ride. You'll find many helpful recommendations throughout this manual. Following are a few that we consider most important.

Always Wear a Helmet

It's a proven fact: helmets significantly reduce the number and severity of head injuries. So always wear an approved motorcycle helmet. We also recommend that you wear eye protection, sturdy boots, gloves and other protective gear (page 3).

Make Yourself Easy to See

Some drivers do not see motorcycles because they are not looking for them. To make yourself more visible, wear bright reflective clothing, position yourself so other drivers can see you, signal before turning or changing lanes, and use your horn when it will help others notice you.

Never Carry a Passenger

Your motorcycle is designed for one person only. There are no handholds, footrests, or seat for a second person—so never carry a passenger. A passenger could interfere with your ability to move around to maintain your balance and control of the motorcycle.

MOTORCYCLE SAFETY

Ride Within Your Limits

Pushing the limits is another major cause of motorcycle accidents. Never ride beyond your personal abilities or faster than conditions warrant. Remember that alcohol, drugs, fatigue and inattention can significantly reduce your ability to make good judgements and ride safely.

Don't Drink and Ride

Alcohol and riding don't mix. Even one drink can reduce your ability to respond to changing conditions, and your reaction time gets worse with every additional drink. So don't drink and ride, and don't let your friends drink and ride either.

Keep Your Bike in Safe Condition

For safe riding, it's important to inspect your motorcycle before every ride and perform all recommended maintenance. Never exceed load limits, and only use accessories that have been approved by Honda for this motorcycle. See page 5 for more details.

PROTECTIVE APPAREL

For your safety, we strongly recommend that you always wear an approved motorcycle helmet, eye protection, boots, gloves, long pants, and a long-sleeved shirt or jacket whenever you ride. Although complete protection is not possible, wearing proper gear can reduce the chance of injury when you ride.

Following are suggestions to help you choose proper gear.

WARNING

Not wearing a helmet increases the chance of serious injury or death in a crash.

Be sure you always wear a helmet, eye protection and other protective apparel when you ride.

Helmets and Eye Protection

Your helmet is your most important piece of riding gear because it offers the best protection against head injuries. A helmet should fit your head comfortably and securely. A bright-coloured helmet can make you more noticeable in traffic, as can reflective strips.

An open-face helmet offers some protection, but a full-face helmet offers more. Always wear a face shield or goggles to protect your eyes and help your vision.

Additional Riding Gear

In addition to a helmet and eye protection, we also recommend:

- Sturdy boots with non-slip soles to help protect your feet and ankles.
- Leather gloves to keep your hands warm and help prevent blisters, cuts, burns and bruises.
- A motorcycle riding suit or jacket for comfort as well as protection. Bright-coloured and reflective clothing can help make you more noticeable in traffic. Be sure to avoid loose clothes that could get caught on any part of your motorcycle.

MOTORCYCLE SAFETY

LOAD LIMITS AND GUIDELINES

This motorcycle has been designed to carry a rider and a limited amount of cargo. When you carry cargo, you may feel some difference during acceleration, high speed operation and braking. But so long as the motorcycle is kept well-maintained, with good tyres and brakes, you can safely carry loads within the given limits and guidelines.

However, exceeding the weight limit or carrying an unbalanced load can seriously impair this motorcycle's handling, braking, and stability. Improperly adding equipment, improper modifications, and poor maintenance can also reduce your safety margin.

Loading

How much weight you put on this motorcycle, and how it is loaded are important to your safety. Anytime you ride with cargo, you should be aware of the information below and on the following page.

WARNING

Overloading or improper loading can cause a crash and you can be seriously hurt or killed.

Follow all load limits and other loading guidelines in this manual.

Load Limits

Following are the load limits for your motorcycle:

Maximum weight capacity: = 146 kg (322 lbs)
includes the weight of the rider, all
attachments and all cargo

Putting too much weight in individual storage compartments can also affect stability and handling. So be sure to stay within the limits given below:

Maximum compartment weight: = 23.6 kg (52.2 lbs)
includes following maximum
compartment weights:

rear cowl (radio only, no storage)	= 6.0 kg (13.2 lbs)
each saddlebag	= 6.8 kg (15.0 lbs)
each fairing pocket	= 2.0 kg (4.5 lbs)

Loading Guidelines

Improperly loading this motorcycle can affect its stability and handling. Even if the motorcycle is properly loaded, you should ride at reduced speeds when carrying cargo.

Follow these guidelines whenever you ride with cargo:

- Check that both tyres are properly inflated (page 41).
- If you change your normal load, you may need to adjust your rear suspension settings (page 28) and your headlight (page 61).
- To prevent loose items from creating a hazard, make sure that storage lids are properly closed and that any other cargo is securely tied down before you ride away.

MOTORCYCLE SAFETY

- Cargo weight should be carried as low and as close to the centre of a motorcycle as possible. When loading your motorcycle, try to pack heavier items in the saddlebags and put lighter, bulkier items in the travel trunk. If you must carry heavy items in the trunk, put them as far forward as you can.
- Balance cargo weight evenly on both sides. When loading the saddlebags, for example, be sure the weight in each bag is about the same.

Attachments and Modifications

Modifying this motorcycle or improperly attaching police equipment can make it unsafe. Before making any modifications or attaching any equipment, be sure to read the following information.

WARNING

Improper modifications or addition of police equipment can cause a crash in which you can be seriously hurt or killed.

Follow all instructions in this owner's manual regarding attachments and modifications.

Attachments

Because Honda cannot test all available equipment or combinations of equipment that may be required for use on a police vehicle, you and your department must be responsible for the proper selection, installation, and use of equipment attached to this vehicle.

We strongly recommend that qualified personnel evaluates a motorcycle fitted with all required police equipment under the anticipated conditions before the vehicle is placed into service.

Always follow these guidelines:

- Make sure any added equipment does not obscure any lights, reduce ground clearance and lean angle, limit suspension travel or steering travel, alter riding position, or interfere with operating any controls.

-
- Be sure electrical equipment does not exceed the motorcycle's electrical system capacity (page 125). A blown fuse can cause a loss of lights or engine power.
 - Do not pull a trailer or sidecar with your motorcycle. This motorcycle was not designed for these attachments, and their use can seriously impair your motorcycle's handling.

Modifications

We strongly advise you not to remove any original equipment or modify your motorcycle in any way that would change its design or operation. Such changes could seriously impair your motorcycle's handling, stability and braking, making it unsafe to ride.

Removing or modifying your lights, mufflers, emission control system or other equipment can also make your motorcycle illegal.

MOTORCYCLE SAFETY

SAFETY LABELS

The following pages show the locations of safety labels on your motorcycle. Some labels warn you of potential hazards that could cause serious injury. Others provide important safety information. Read these labels carefully and don't remove them.

If a label comes off or becomes hard to read, contact your Honda dealer for a replacement.

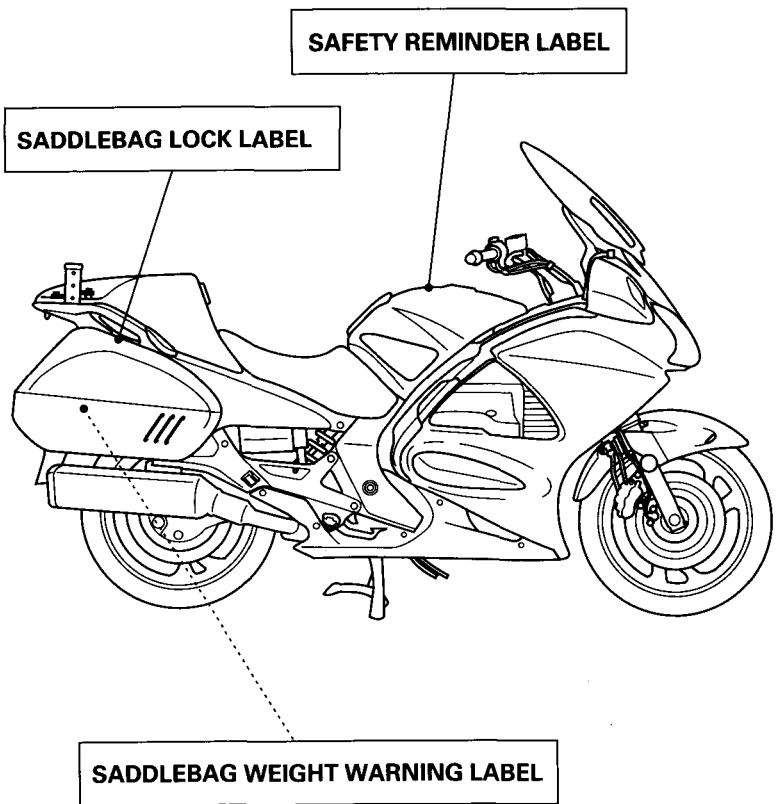

SADDLEBAG LOCK LABEL

LOADING WARNING LABEL

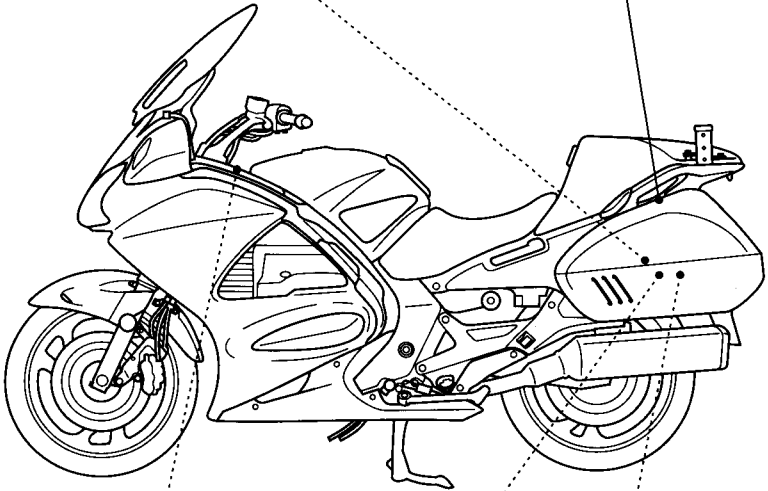

CARGO LIMIT

2.0 kg (4.5 lbs)

CARGO LIMIT

6.8 kg (15.0 lbs)

SADDLEBAG WEIGHT WARNING LABEL

MOTORCYCLE SAFETY

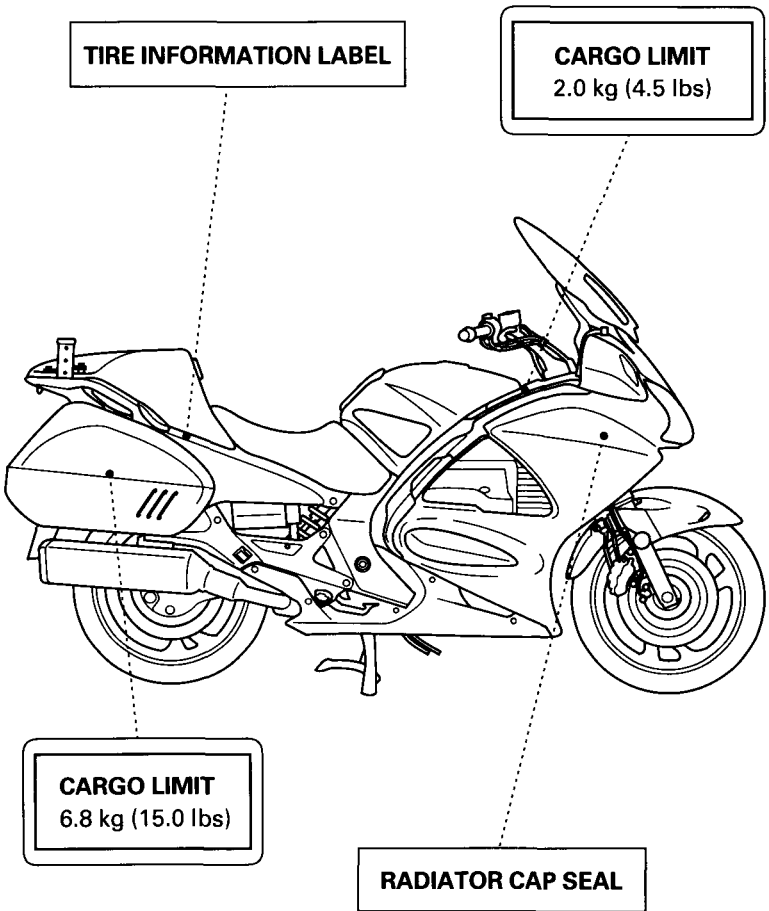

PARTS LOCATION

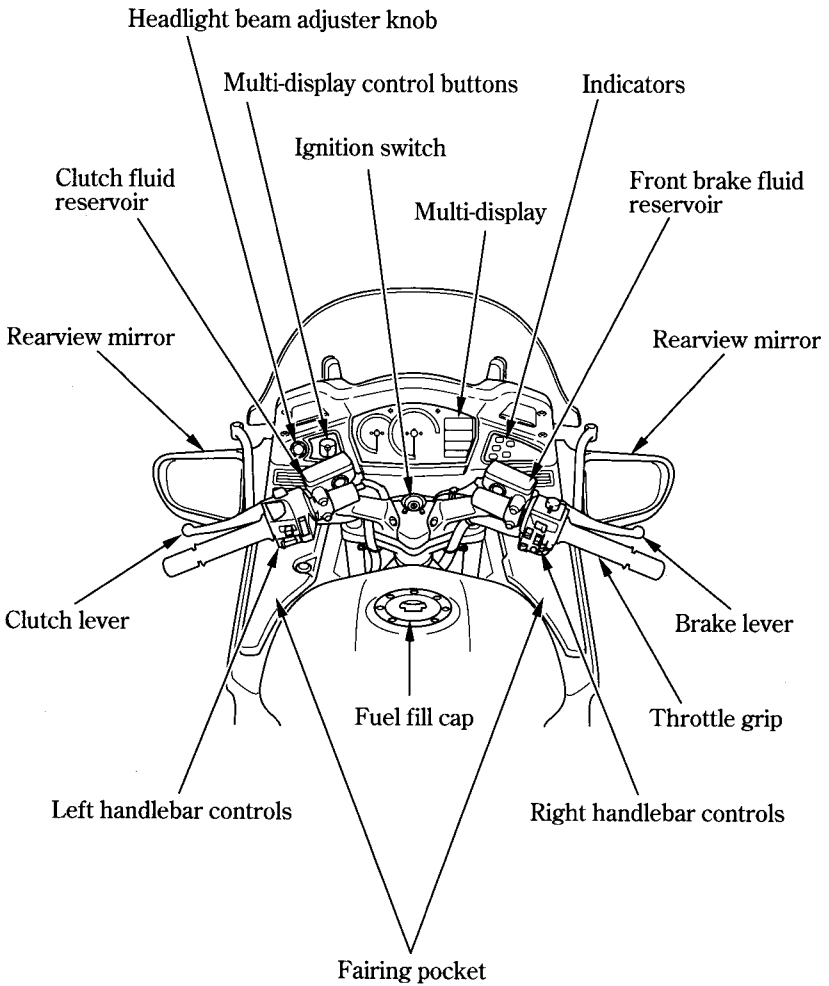

PARTS LOCATION

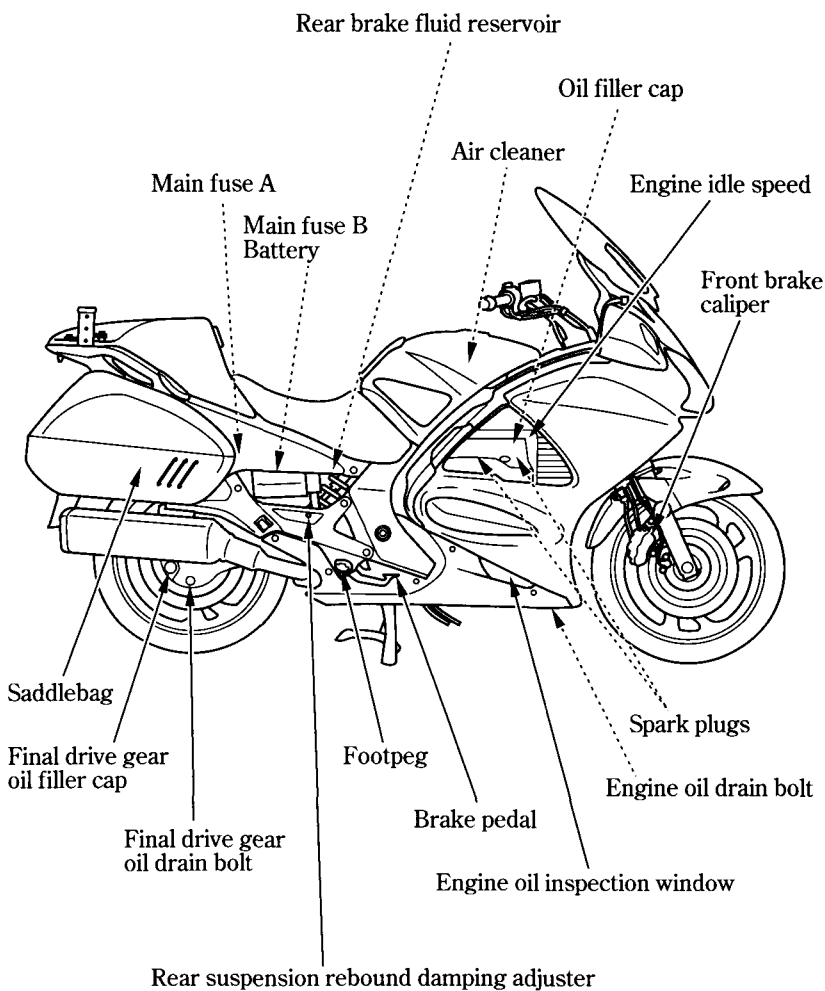

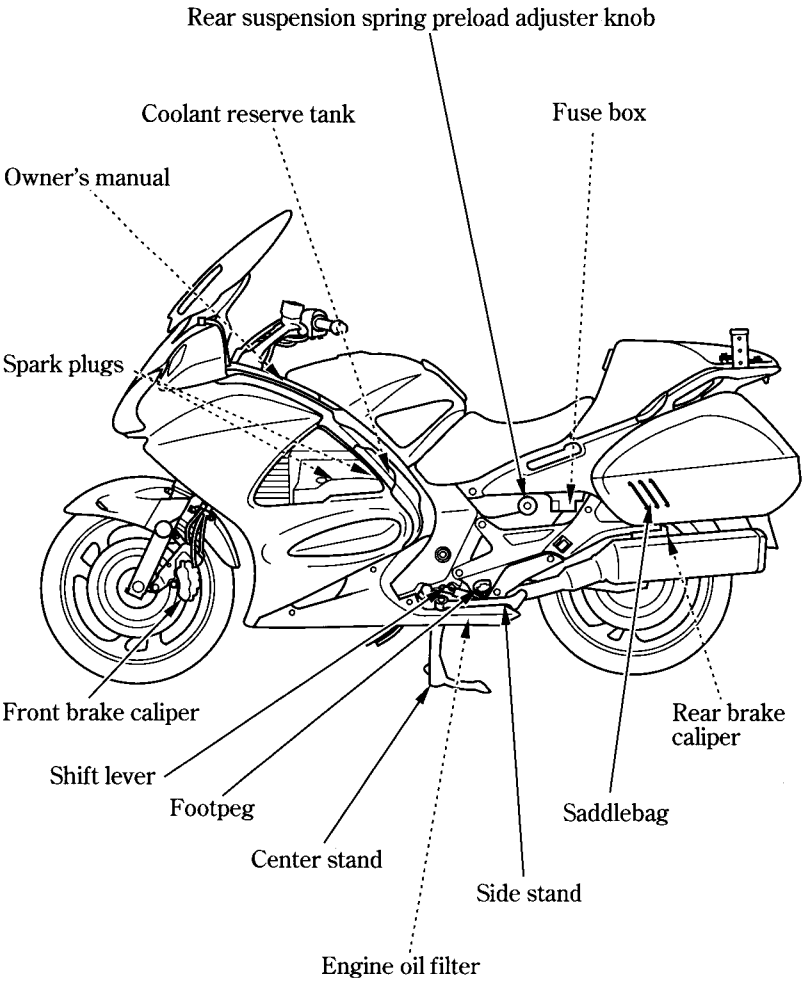

PARTS LOCATION

INSTRUMENTS AND INDICATORS

The indicators are contained in the instrument panel. Their functions are described in the tables on the following pages.

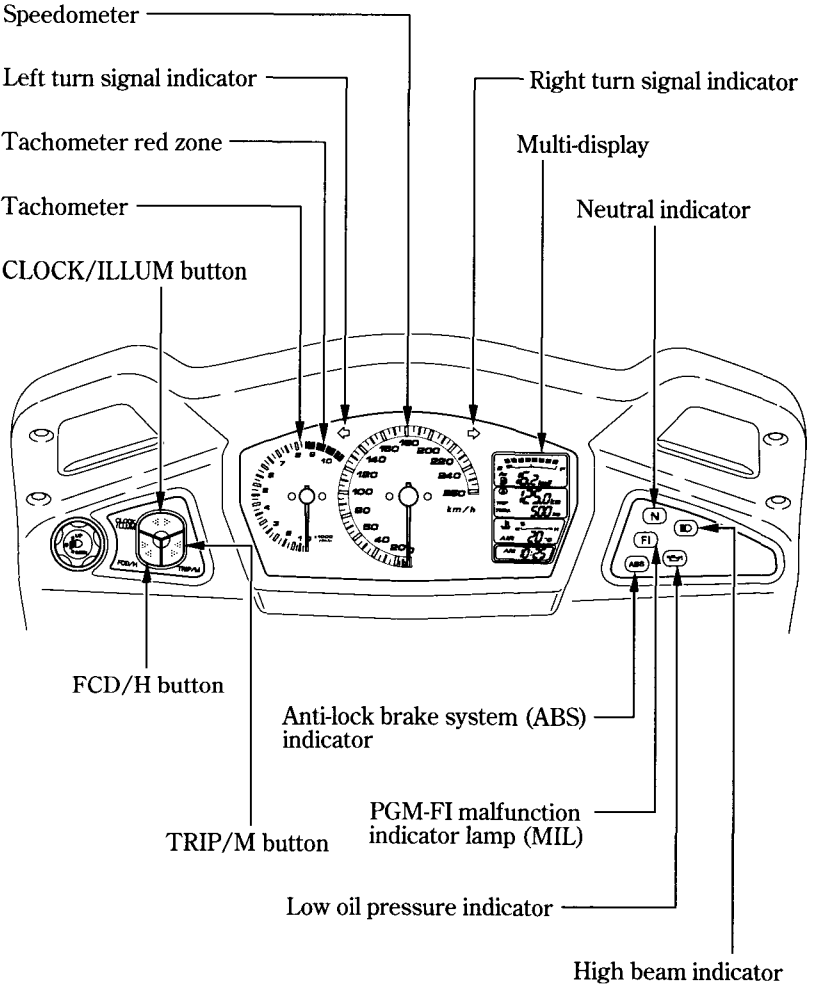



Speedometer

Shows riding speed.



Tachometer

Shows engine speed in revolutions per minute.



Tachometer red zone

Never allow the tachometer needle to enter the red zone, even after the engine has been broken in.

NOTICE

Running the engine beyond recommended maximum engine speed (the beginning of the tachometer red zone) can damage the engine.



Turn Signal Indicators (green)

Flashes when a turn signal operates.



Neutral indicator (green)

Lights when the transmission is in neutral.

PARTS LOCATION



Low oil pressure indicator (red)

Lights when the engine oil pressure is below normal operating range. Should light when ignition switch is ON and engine is not running. Should go out when the engine starts, except for occasional flickering at or near idling speed when engine is warm.

NOTICE

Running the engine with insufficient oil pressure may cause serious engine damage.



PGM-FI malfunction indicator lamp (MIL) (red)

Lights when there is any abnormality in the PGM-FI (Programmed Fuel Injection) system. Should also light for a few seconds and then go off when the ignition switch is turned ON and engine stop switch is at \odot (RUN). If the indicator comes on at any other time, reduce speed and take the motorcycle to a Honda dealer as soon as possible.



Anti-lock brake system (ABS) Indicator (red)

This light normally comes on when the ignition is turned ON, and goes off after you ride the motorcycle at speed above 10 km/h (6 mph). If there is a problem with the Anti-lock Brake System, this light flashes and remains on (page 72).



High beam indicator (blue)

Lights when the headlight is on high beam.

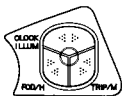

CLOCK/ILLUM button

Use this button for the following purposes.

- To adjust time
- To adjust display illumination

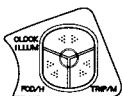

FCD/H button

Use this button for the following purposes.

- To adjust time
- To select and reset the fuel mileage meter
- To change the mileage units for the odometer/tripmeter and fuel consumption meter

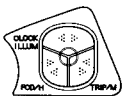

TRIP/M button

Use the button for the following purposes.

- To adjust time
- To select and reset the tripmeter

PARTS LOCATION

MULTI-DISPLAY

Your motorcycle is equipped with a *Multi-display* that presents various displays. This section explains display functions and operations.

Initial Display

When the ignition switch is turned ON, the display will temporarily show all the modes and digital segments so you can make sure the liquid crystal display is functioning properly. (Except digital clock)

Digital clock and tripmeter will reset if the battery is disconnected.

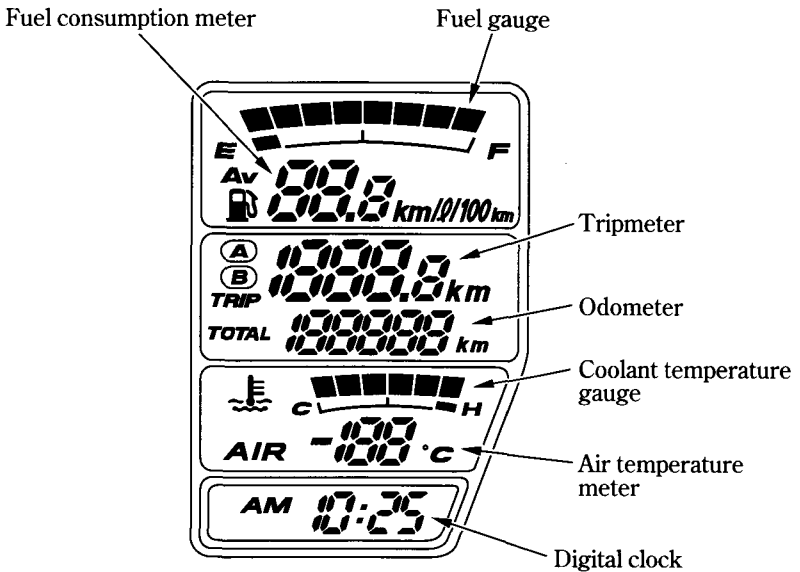

Fuel Gauge

The fuel gauge liquid crystal display shows the approximate fuel supply available in a graduated display. When the segment F goes on, the fuel tank capacity including reserve is:

29.0 l (7.66 US gal , 6.38 Imp gal)

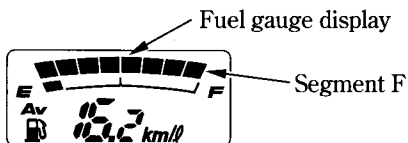

When segment E flashes, fuel will be low and you should refill the tank as soon as possible. The amount of fuel left in the tank with the vehicle set upright is approximately:

5.0 l (1.32 US gal , 1.10 Imp gal)

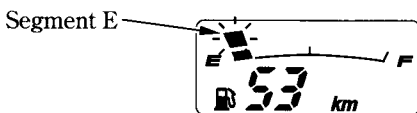

Coolant Temperature Gauge

When the segment begins to move above the C (Cold) mark, the engine is warm enough for the motorcycle to be ridden. The normal operating temperature range is within the section between the H and C marks.

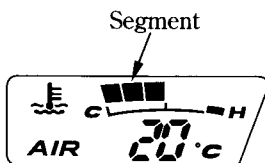

If the segment H flashes, stop the engine and check the reserve tank coolant level. Read pages 34 – 35 and do not ride the motorcycle until the problem has been corrected.

NOTICE

Exceeding maximum running temperature may cause serious engine damage.

PARTS LOCATION

Air Temperature Meter

Air temperature meter shows air temperature digitally.

Temperature Display

Below -10°C	“— —” is displayed.
Between: -10°C — 50°C	Actual air temperature is indicated.
Above 50°C	The display will remain and blink “ 50°C ”.

The temperature sensor is located in the fairing. The temperature reading can be affected by heat reflecting from the road surface, engine heat, and the exhaust from surrounding traffic. This can cause an error in the temperature reading when your speed is under 30 km/h (19 mph).

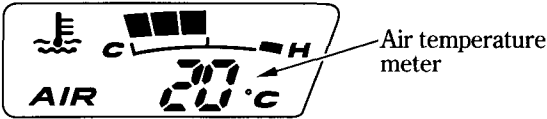

Fuel consumption meter

The fuel consumption meter allows indication of the available driving distance, the amount of remaining fuel, the current fuel consumption and the average fuel consumption. Briefly pressing the FCD/H button changes the indication as described below. The available driving distance and the amount of remaining fuel are indicated when the fuel in the fuel tank becomes 5 liters or less.

《When more than 5 liters》

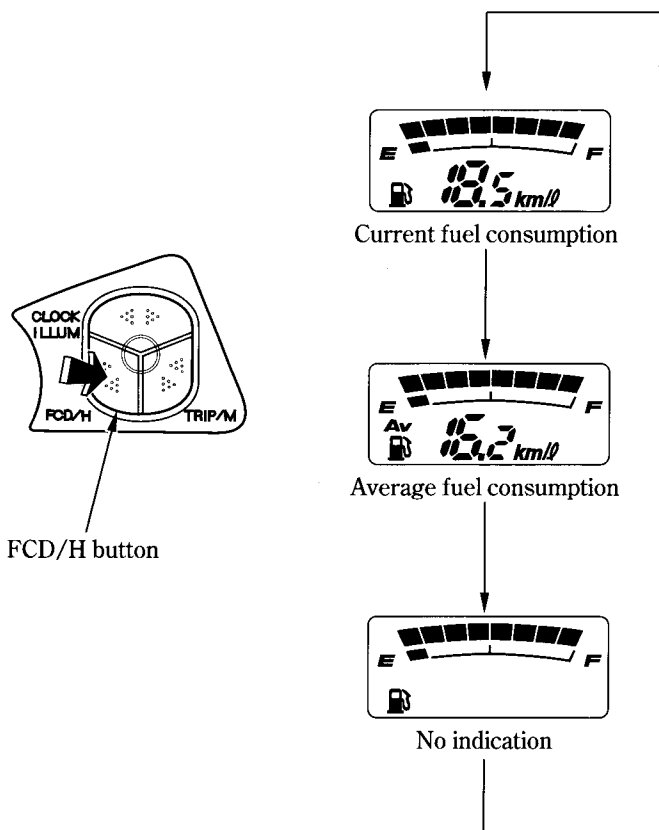

PARTS LOCATION

《When less than 5 liters》

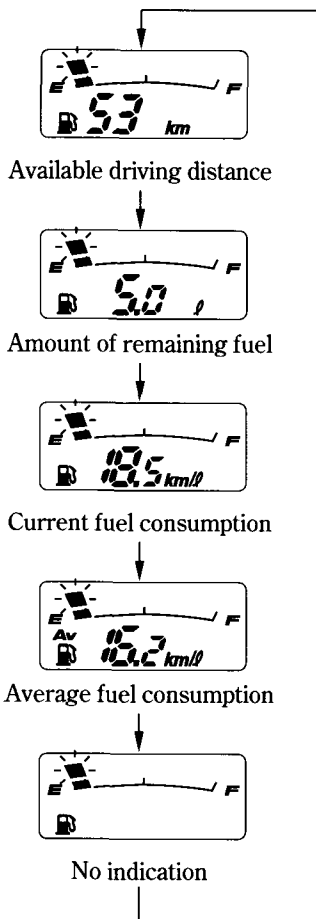
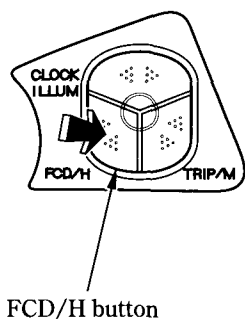

- When the remaining fuel becomes 5 liters or less, the indication automatically changes to the available driving distance.
(Except no indication)
- When the battery terminal is disconnected, the available driving distance, the amount of remaining fuel and the average fuel consumption will be reset.
- When the battery terminal is disconnected with 5 liters or less fuel remaining, the available driving distance and the amount of remaining fuel may be shown inaccurately in some cases.

Current fuel consumption

Indicates the momentary fuel consumption of each 15 seconds during engine operation. With motorcycle speed 5 km/h or below “-” is displayed.

The indicated fuel consumption may differ from the actual fuel consumption.

When “-” blinks, go to your Honda dealer.

Current fuel consumption



Average fuel consumption

The average fuel consumption after reset until that moment is indicated every 15 seconds.

The indicated fuel consumption may differ from the actual fuel consumption.

When “-” blinks, go to your Honda dealer.

Average fuel consumption



To reset average fuel consumption:

Press and hold the FCD/H button with the display in the average fuel consumption.

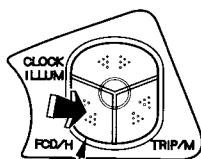

FCD/H button

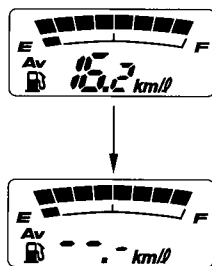

PARTS LOCATION

Available driving distance

When the amount of remaining fuel becomes less than 5 liters, the estimated allowable distance is indicated.

The E type uses mile or km, and others use km.

When the amount of remaining fuel becomes less than 2 liters, “-” will be indicated.

The indicated available driving distance is by calculation depending on the driving conditions, and the indicated figure may not always be the actual allowable distance. When the fuel gauge near to E or when E segment blinks, fill fuel promptly.

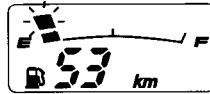

Remaining fuel

When the amount of remaining fuel becomes less than 5 liters, the estimated amount of remaining fuel is indicated.

When the amount of remaining fuel becomes less than 2 liters, “-” will be indicated.

The amount of remaining fuel is calculated from the driving conditions.

The indicated amount of remaining fuel may be different from the actual amount. When the fuel gauge near to E or when E segment blinks, fill fuel promptly.

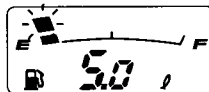

Odometer/Tripmeter

- ODO (Odometer) — Shows accumulated mileage.
- TRIP (Tripmeter) — Shows mileage per trip.

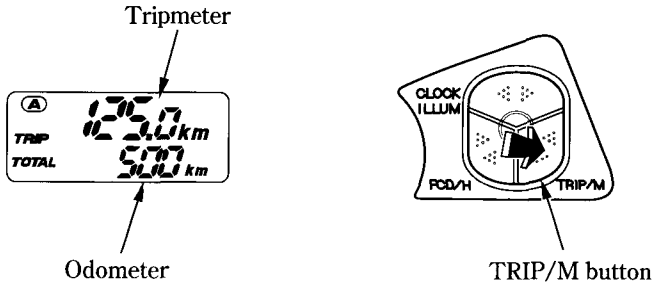

The tripmeter will show mileage in two sub modes, “tripmeter A” and “tripmeter B.”

Push the TRIP/M button to select the “tripmeter A” or “tripmeter B” mode.

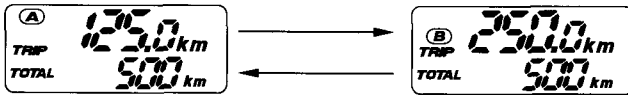

To reset the tripmeter, push and hold the TRIP/M button with the display in the “tripmeter A” or “tripmeter B” mode.



PARTS LOCATION

Digital Clock

The display shows the hour and minute.

To adjust the time:

1. Turn the ignition switch to ON or ACC.
2. Press and hold the CLOCK/ILLUM button for more than 2 seconds. The clock will be set in the adjust mode with the display flashing.
3. To set the hour, press and release the FCD/H button until the desired hour appears.
 - Quick setting — push and hold the FCD/H button until the desired hour appears.
4. To set the minute, press and release the TRIP/M button until the desired minute appears.
 - Quick setting — push and hold the TRIP/M button until the desired minute appears.
5. To end the adjustment, press the CLOCK/ILLUM button after the last adjustment, or turn the ignition switch OFF.

After turning ignition switch OFF, the clock will display for ten days.

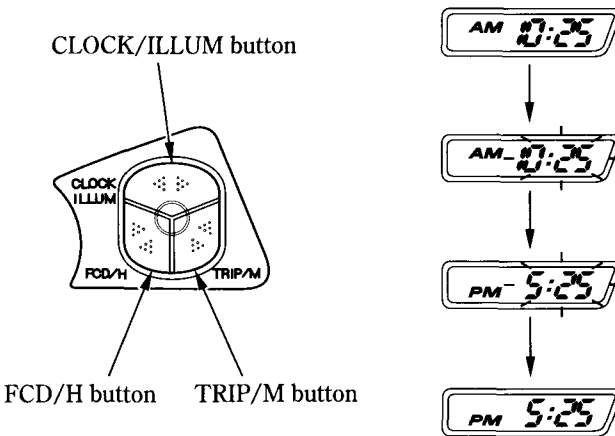

Fuel Consumption Unit Change

The current/average fuel consumption meter displays either “km/ℓ” or “ℓ/100 km”.

Press the FCD/H button to get the fuel consumption meter display shown below.

Press and hold the FCD/H button for more than 2 seconds to select.

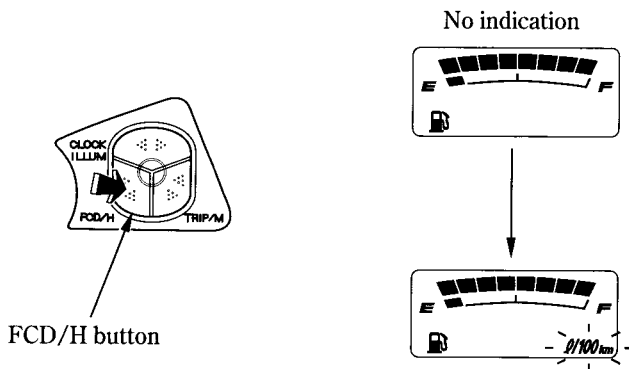

Display Illumination Adjustment

The brightness of a display can be adjusted in three stages.

To adjust the brightness of the display, push the CLOCK/ILLUM button.

CLOCK/ILLUM button

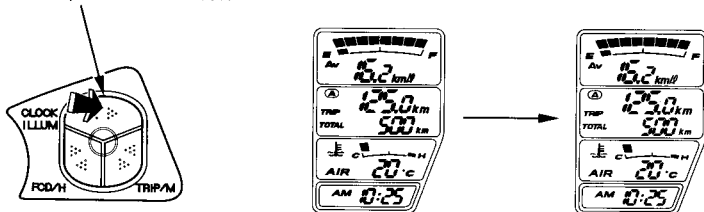

MAJOR COMPONENTS

(Information you need to operate this motorcycle)

REAR SUSPENSION

Rebound Damping:

To reduce (SOFT) :

Turn the adjuster counterclockwise toward SOFT for a light load and smooth road condition.

To increase (HARD) :

Turn the adjuster clockwise toward HARD for a firmer ride and rough road condition.

To adjust the adjuster to the standard position, proceed as follows :

1. Turn the damping adjuster clockwise until it will no longer turn (lightly seats). This is the full hard setting.
2. The adjuster is set in the standard position when the adjuster is turned counterclockwise approximately 1/2 turn so that its punch mark aligns with the reference punch mark.

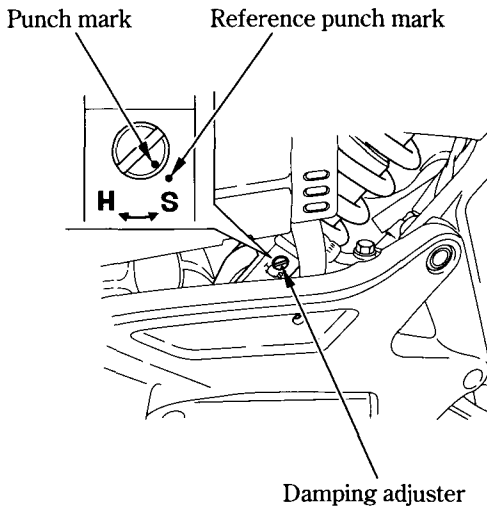

Spring Preload:

The spring preload adjuster knob has 35 spring preload positions (clicks) or more for different load or riding conditions.

To adjust the spring preload, turn the adjuster knob.

To reduce (LOW) :

Turn the adjuster counterclockwise toward LOW for a light load and smooth road condition.

To increase (HIGH) :

Turn the adjuster clockwise toward HIGH for a firmer ride and rough road condition.

To adjust to the standard position:

Turn the spring preload adjuster knob counterclockwise until it will no longer turn (lightly seats). This is the full LOW setting. Turn the adjuster clockwise by 14 clicks. At that position, the end of the adjuster knob should be aligned with the indicator line.

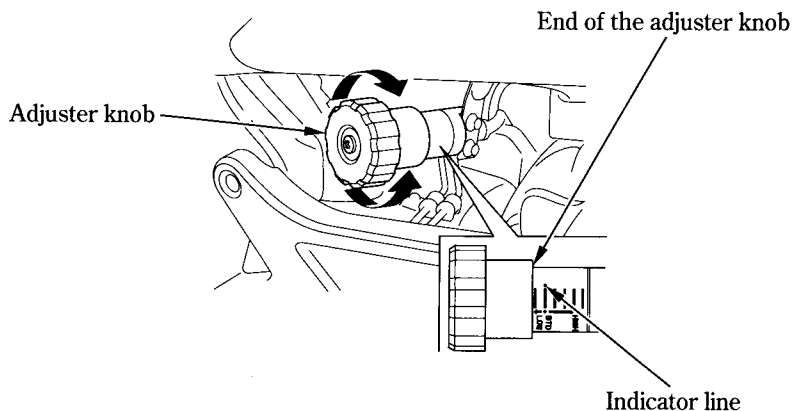

The rear shock absorber assembly includes a damper unit that contains high pressure nitrogen gas. Do not attempt to disassemble or service the damper; it cannot be rebuilt and must be replaced when worn out. Disposal should only be done by your Honda dealer. The instructions found in this owner's manual are limited to adjustment of the shock assembly only.

MAJOR COMPONENTS

(Information you need to operate this motorcycle)

BRAKES

Both the front and rear brakes are the hydraulic disc types.

As the brake pads wear, the brake fluid level drops.

There are no adjustments to perform, but fluid level and pad wear must be inspected periodically. The system must be inspected frequently to ensure there are no fluid leaks. If the control lever or pedal free travel becomes excessive and the brake pads are not worn beyond the recommended limit (page 108), there is probably air in the brake system and it must be bled. See your Honda dealer for this service.

Front Brake Fluid Level:

With the motorcycle in an upright position, check the fluid level. It should be above the LOWER level mark. If the level is at or below the LOWER level mark, check the brake pads for wear (page 108).

Worn pads should be replaced. If the pads are not worn, have your brake system inspected for leaks.

The recommended brake fluid is Honda DOT 4 brake fluid from a sealed container, or an equivalent.

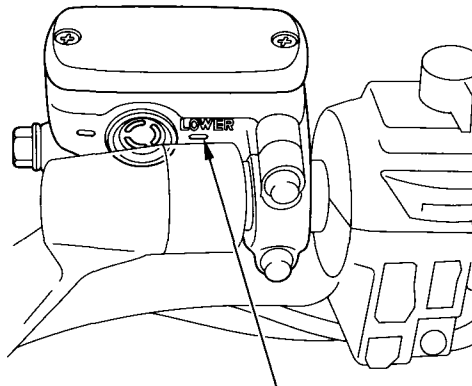

LOWER level mark

The distance between the tip of the brake lever and the grip may be adjusted.

1. Turn the adjuster dial while pushing the brake lever forward.
2. Align the index mark on the brake lever with the numbers on the adjuster dial.
3. Apply the brake, release it, then spin the wheel and check that it rotates freely. Repeat this procedure several times.

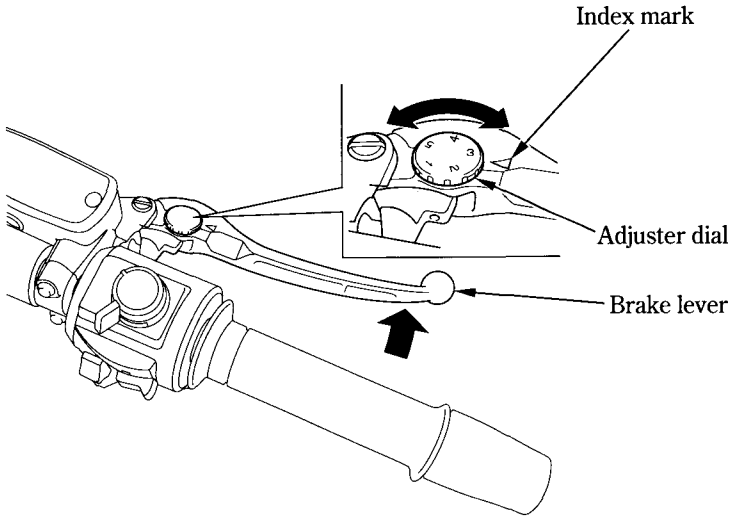

Other Checks:

Make sure there are no fluid leaks. Check for deterioration or cracks in the hoses and fittings.

MAJOR COMPONENTS

(Information you need to operate this motorcycle)

Rear Brake Fluid Level:

The reserve tank is located below the seat.

Remove the seat (page 53).

With the motorcycle in an upright position, check the fluid level. It should be between the UPPER and LOWER level marks. If the level is at or below the LOWER level mark, check the brake pads for wear (page 108).

Worn pads should be replaced. If the pads are not worn, have your brake system inspected for leaks.

The recommended brake fluid is Honda DOT 4 brake fluid from a sealed container, or an equivalent.

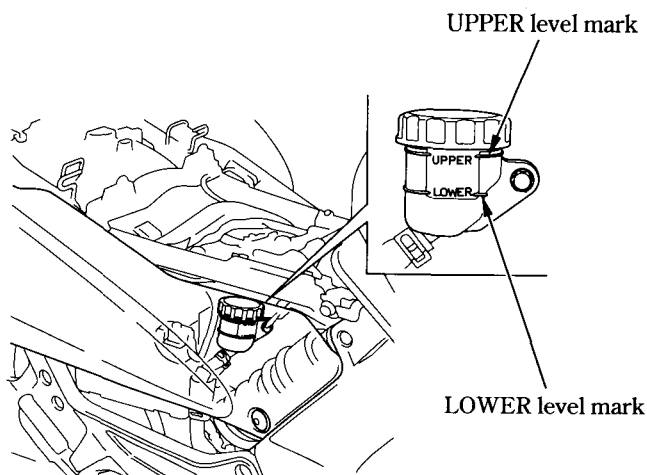

Other Checks:

Make sure there are no fluid leaks. Check for deterioration or cracks in the hoses and fittings.

CLUTCH

This motorcycle has a hydraulically actuated clutch. There are no adjustments to perform, but the clutch system must be inspected periodically for fluid level and leakage.

If the motorcycle creeps or stalls when shifted into gear, or if the clutch slips, causing acceleration to lag behind engine speed, there is probably air in the clutch system and it must be bled out. See your Honda dealer for this service.

Fluid Level:

Check that the fluid level is above the LOWER level mark. If the fluid level is near the LOWER level mark, it indicates fluid leakage. See your Honda dealer for repair.

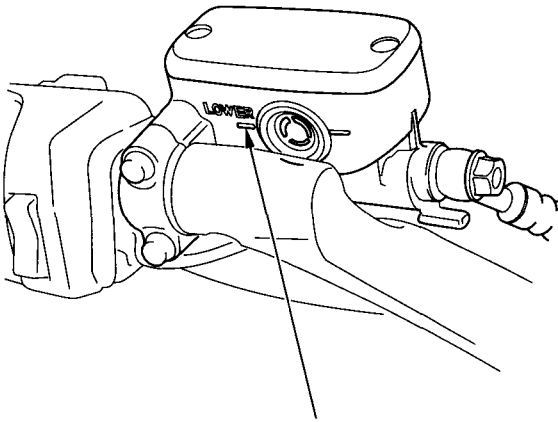

LOWER level mark

Other Checks:

Make sure there are no fluid leaks. Check for deterioration or cracks in the hoses and fittings.

MAJOR COMPONENTS

(Information you need to operate this motorcycle)

COOLANT

Coolant Recommendation

The owner must properly maintain the coolant to prevent freezing, overheating, and corrosion. Use only high quality ethylene glycol antifreeze containing corrosion protection inhibitors specifically recommended for use in aluminum engines. (SEE ANTIFREEZE CONTAINER LABEL).

Use only low-mineral drinking water or distilled water as a part of the antifreeze solution. Water that is high in mineral content or salt may be harmful to the aluminum engine.

NOTICE

Using coolant with silicate inhibitors may cause premature wear of water pump seals or blockage of radiator passages.

Using tap water may cause engine damage.

The factory provides a 50/50 solution of antifreeze and distilled water in this motorcycle. This coolant solution is recommended for most operating temperatures and provides good corrosion protection. A higher concentration of antifreeze decreases the cooling system performance and is recommended only when additional protection against freezing is needed. A concentration of less than 40/60 (40% antifreeze) will not provide proper corrosion protection. During freezing temperatures, check the cooling system frequently and add higher concentrations of antifreeze (up to a maximum of 60% antifreeze) if required.

Inspection

The reserve tank is located below the maintenance lid.

Remove the left maintenance lid (page 83).

Check the coolant level in the reserve tank while the engine is at normal operating temperature. Add coolant to the reserve tank as required to bring coolant level to the UPPER level mark. Always add coolant to the reserve tank.

Do not attempt to add coolant by removing the radiator cap.

If the reserve tank is empty, or if coolant loss is excessive, check for leaks and see your Honda dealer for repair.

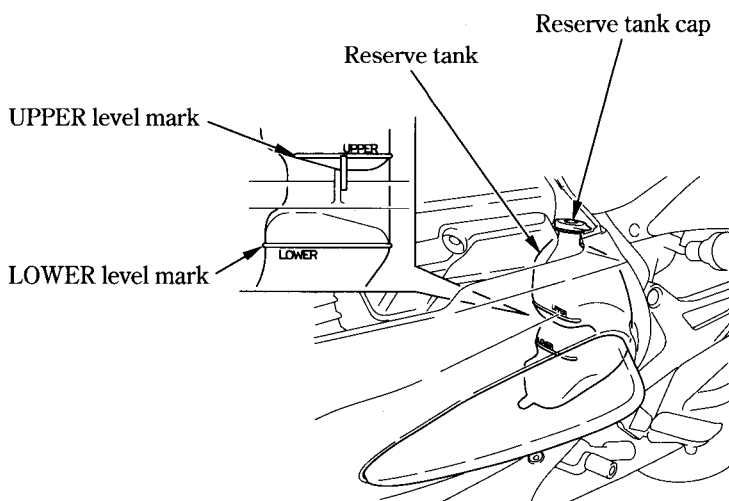

MAJOR COMPONENTS

(Information you need to operate this motorcycle)

FUEL

Fuel Tank

The fuel tank capacity including the reserve supply is:

29.0 ℓ (7.66 US gal , 6.38 Imp gal)

To open the fuel fill cap, insert the ignition key and turn it clockwise. The fuel fill cap is hinged and will lift up.

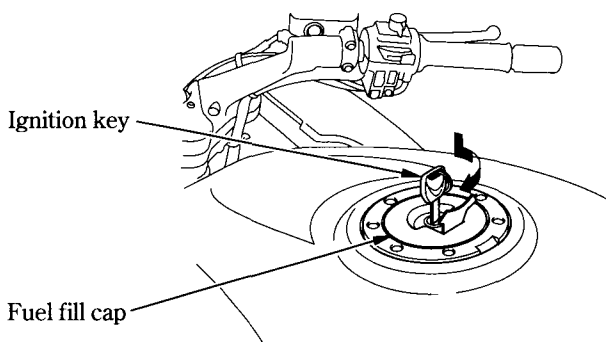

Use premium unleaded petrol with a research octane number of 95 or higher. The use of leaded petrol will cause premature damage to the catalytic converter.

NOTICE

If “spark knock” or “pinking” occurs at a steady engine speed under normal load, change brands of petrol. If spark knock or pinking persists, consult your Honda dealer. Failure to do so is considered misuse, and damage caused by misuse is not covered by Honda’s Limited Warranty.

Occasionally you may experience light spark knock while operating under heavy loads. This is no cause for concern, it simply means your engine is operating efficiently.

Do not overfill the tank. There should be no fuel in the filler neck.

After refueling, to close the fuel fill cap, push the fuel fill cap into the filler neck until it snaps closed and locks. Remove the key.

⚠ WARNING

Petrol is highly flammable and explosive. You can be burned or seriously injured when handling fuel.

- Stop the engine and keep heat, sparks, and flame away.
- Refuel only outdoors.
- Wipe up spills immediately.

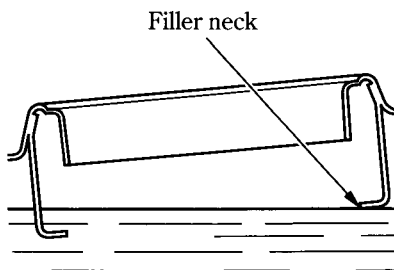

MAJOR COMPONENTS

(Information you need to operate this motorcycle)

Petrol Containing Alcohol

If you decide to use a petrol containing alcohol (gasohol), be sure it's octane rating is at least as high as that recommended by Honda. There are two types of "gasohol": one containing ethanol, and the other containing methanol. Do not use petrol that contains more than 10 % ethanol. Do not use petrol containing methanol (methyl or wood alcohol) that does not also contain cosolvents and corrosion inhibitors for methanol. Never use petrol containing more than 5 % methanol, even if it has cosolvents and corrosion inhibitors.

Fuel system damage or engine performance problems resulting from the use of fuels that contain alcohol is not covered under the warranty. Honda cannot endorse the use of fuels containing methanol since evidence of their suitability is as yet incomplete.

Before buying fuel from an unfamiliar station, try to find out if the fuel contains alcohol. If it does, confirm the type and percentage of alcohol used. If you notice any undesirable operating symptoms while using a petrol that contains alcohol, or one that you think contains alcohol, switch to a petrol that you know does not contain alcohol.

ENGINE OIL

Engine Oil Level Check

Check the engine oil level each day before riding the motorcycle. The level must be maintained between the upper and lower level marks in the inspection window.

To Check the Oil Level:

1. Start the engine and let it idle for 3–5 minutes. Make sure the low oil pressure indicator goes off. If the indicator remains flashing, stop the engine immediately.
2. Stop the engine and put the motorcycle on its center stand on level ground.
3. After 2–3 minutes, check that the oil level is between the upper and lower level marks in the inspection window.
4. If required, remove the right maintenance lid (page 83), overhead cover (page 85) and oil filler cap and add the specified oil up to the upper level mark. Do not overfill.
5. Reinstall the oil filler cap, overhead cover and right maintenance lid. Check for oil leaks.

NOTICE

Running the engine with insufficient oil can cause serious engine damage.

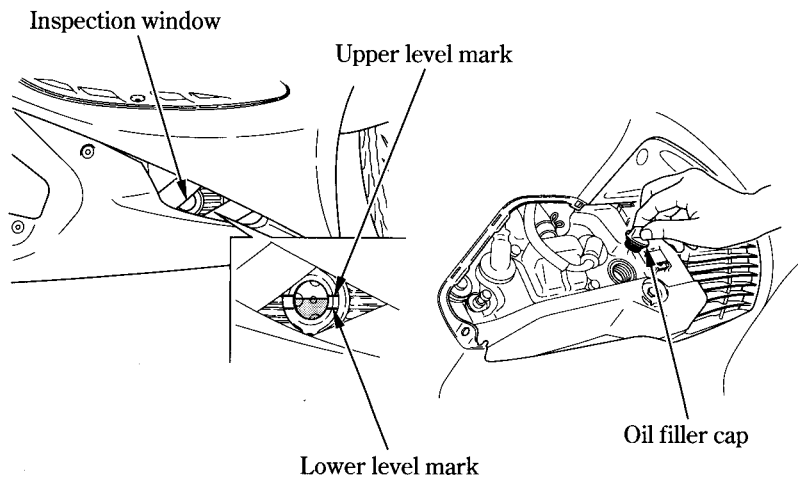

MAJOR COMPONENTS

(Information you need to operate this motorcycle)

FINAL DRIVE OIL

Oil Level Check

Check the final drive oil level when specified by the maintenance schedule (page 79).

1. Place the motorcycle on its center stand on a firm, level surface.
2. Remove the oil filler cap.
3. Check the oil level. It should be flush with the lower edge of the oil filler hole.
4. If the level is low, check for oil leaks. Add the recommended oil through the oil filler hole until it reaches the lower edge of the opening.
5. Install the oil filler cap.

Recommended Oil:
HYPOID GEAR OIL SAE 80

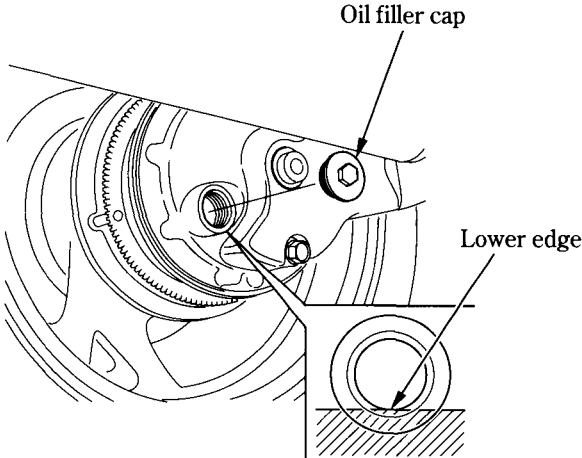

TUBELESS TYRES

To safely operate your motorcycle, your tyres must be the proper type and size, in good condition with adequate tread, and correctly inflated for the load you are carrying. The following pages give more detailed information on how and when to check your air pressure, how to inspect your tyres for damage, and what to do when your tyres need to be repaired or replaced.

⚠ WARNING

Using tyres that are excessively worn or improperly inflated can cause a crash in which you can be seriously hurt or killed.

Follow all instructions in this owner's manual regarding tyre inflation and maintenance.

Air Pressure

Keeping your tyres properly inflated provides the best combination of handling, tread life and riding comfort. Generally, underinflated tyres wear unevenly, adversely affect handling, and are more likely to fail from being overheated. Overinflated tyres make your motorcycle ride harshly, are more prone to damage from road hazards, and wear unevenly.

We recommend that you visually check your tyres before every ride and use a gauge to measure air pressure at least once a month or any time you think the tyres might be low.

Tubeless tyres have some self-sealing ability if they are punctured. However, because leakage is often very slow, you should look closely for punctures whenever a tyre is not fully inflated.

MAJOR COMPONENTS

(Information you need to operate this motorcycle)

Always check air pressure when your tyres are “cold” – when the motorcycle has been parked for at least three hours. If you check air pressure when your tyres are “warm” – when the motorcycle has been ridden for even a few miles – the readings will be higher than if the tyres were “cold”. This is normal, so do not let air out of the tyres to match the recommended cold air pressures given below. If you do, the tyres will be underinflated.

The recommended “cold” tyre pressures are:

Front	290 kPa (2.90 kgf/cm ² , 42 psi)
Rear	290 kPa (2.90 kgf/cm ² , 42 psi)

Inspection

Whenever you check the tyre pressures, you should also examine the tyre treads and sidewalls for wear, damage, and foreign objects:

Look for:

- Bumps or bulges in the side of the tyre or the tread. Replace the tyre if you find any bumps or bulges.
- Cuts, splits or cracks in the tyre. Replace the tyre if you can see fabric or cord.
- Excessive tread wear.

Also, if you hit a pothole or hard object, pull to the side of the road as soon as you safely can and carefully inspect the tyres for damage.